



LGMG North America Inc.

Operation and Safety Manual

**SS1432E/SS1932E/AS2632E
/AS4046E**

**Mobile Elevating Work Platform
(Indoor Use Only)
ANSI**

 **WARNING**

Before operation and maintenance, the drivers and service personnel shall always read and thoroughly understand all information in this manual. Failure to do so may result in, fatal accidents or personal injury.

This manual must be kept with this machine at all times.

This page left blank intentionally

Foreword

Thank you for choosing to use this Mobile Elevating Work Platform from LGMG North America. The information specified in this manual is intended for the safe and proper operation of this machine for its' intended purpose.

For maximum performance and utilization of this machine, thoroughly read and understand all the information in this manual before starting, operating, or performing maintenance on this machine.

Due to continuous product improvements, LGMG North America reserves the right to make specification changes without any prior notifications. For any updated information, contact LGMG North America.

Ensure all preventive maintenance to the machine is performed according to the interval specified in the maintenance schedule.

Keep this manual with this machine for reference at all times. When the ownership of this machine is transferred, this manual shall be transferred with this machine. This manual must be replaced immediately if it is lost, damaged, or becomes illegible.

This manual is copyrighted material. The reproduction or copy of this manual is not allowed without the written approval of LGMG North America.

The information, technical specifications and drawings in this manual are the latest available when this manual is issued. Due to continuous improvement, LGMG North America reserves the right to change the technical specifications and machine design without notice. If any specifications and information in the manual are not consistent with your machine, please contact the service department of LGMG North America.



Only personnel who have been properly trained and qualified to operate or maintain this machine can operate, repair and maintain this machine.

Improper operation, maintenance, and repair are dangerous and can cause personal injury and death.

Before any operation or maintenance, the operator shall thoroughly read this manual. Do not operate, perform any maintenance or make any repairs on this machine before reading and understanding this manual.

The user shall load the platform strictly according to the load rating of the platform. Do not overload the platform or make any modifications to the platform without permission from LGMG North America.

The operation regulations and preventions in this manual are only applicable for the specified use of this machine.

Safety Precautions

The operator of this machine shall understand and follow the existing safety regulations of state and local governments. If these are unavailable, the safety instructions in this manual shall be followed.

To help prevent accidents, read and understand all warnings and precautions in this manual before operation or performing maintenance.

The safety measures are specified in Chapter 1 Safety.

It is impossible to foresee every possible hazard and the safety instructions in this manual may not cover all safety prevention measures. Always ensure the safety of all personnel and protect the machine against any damage. If unable to confirm the safety of some operations, contact LGMG North America.

The operation & maintenance prevention measures listed in this manual are only applicable to the specified uses of this machine. LGMG North America assumes no responsibility if this machine is used beyond the range of this manual. The user and the operator shall be responsible for the safety of such operations.

Do not perform any operation forbidden in this manual in any situation.

The following signal words are applicable for identifying the level of safety information in this manual.

 **Danger:**

An imminent situation, that if not avoided, will result in severe injuries or death. This is also applicable to situations that will cause serious machine damage, if not avoided.

 **Warning:**

A potentially dangerous situation, that if not avoided, may result in severe injuries or death. This is also applicable to situations that may cause serious machine damage, if not avoided.

 **Notice:**

A situation, that if not avoided, may result in minor or intermediate injury. This is also applicable to situations that may cause machine damage or shorten machine service life.

Contents

- Chapter 1 Safety..... 1
 - 1.1 Description2
 - 1.2 Maintenance of Safety Signs and Decals2
 - 1.4 Battery Safety.....8
 - 1.5 Lock After Each Use.....9
- Chapter 2 Machine Nomenclature 11
- Chapter 3 Controls..... 13
 - 3.1 Ground Controls 13
 - 3.1.1 Key Switch 13
 - 3.1.2 Emergency Stop Switch..... 13
 - 3.1.3 Platform Lift Switch 13
 - 3.2 Platform Controls..... 14
 - 3.2.1 Horn Button..... 14
 - 3.2.2 Lift Switch 14
 - 3.2.3 Display 14
 - 3.2.4 Emergency Stop Switch..... 14
 - 3.2.5 Drive/Lift Control Lever 15
 - 3.2.6 Drive Speed Button..... 15
 - 3.2.7 Drive Function Button..... 15
 - 3.2.8 Steer Switch..... 15
 - 3.2.9 Enabling Switch..... 15



Chapter 4 Pre-Operation Inspection 17

 4.1 Basic Principles 17

 4.2 Pre-Operation Inspection..... 17

Chapter 5 Workstation Inspection 19

 5.1 General Information..... 19

 5.2 Workstation Inspection 19

Chapter 6 Function Test..... 21

 6.1 General Information..... 21

 6.2 Function Test..... 21

 6.3 Tests from the Ground Controls..... 21

 6.4 Test the Emergency Stop Switch..... 22

 6.5 Test of Lifting/Lowering Function 22

 6.6 Emergency Lowering Function Test 22

6.7 Platform Controller Test..... 22

 6.8 Horn Test 22

 6.9 Lift Function and Function Enable Switch Test 23

 6.10 Steering Test 23

 6.11 Driving and Braking Function Test..... 24

 6.12 Driving Function Test..... 24

 6.13 Operation of Tilt Sensor Test..... 25

 6.14 Pothole Guard Test 26

Chapter 7 Operating Instructions 27

 7.1 General Information..... 27

 7.2 Emergency Stop..... 27

 7.3 Emergency Lowering..... 27

 7.4 Operation from the Ground Controls..... 27



7.5 Platform Positioning.....	28
7.6 Operation from the Platform Controls	28
7.7 Platform Positioning.....	28
7.8 Steering.....	28
7.9 Drive.....	28
7.10 Drive Speed Option	29
7.11 Driving the Machine from the Ground	29
7.12 Using the Safety Prop.....	30
7.13 How to Stow the Guardrail.....	30
7.14 How to Erect the Guardrail	32
7.15 Extending and Retracting the Extending Platform Deck.....	32
7.16 Error Codes.....	33
Chapter 8 Transport and Lifting Instructions	39
8.1 Releasing the Brake	39
8.2 Transport Safety.....	41
8.3 Loading the Machine with a Forklift	42
8.4 Lifting Precautions.....	42
8.5 Parking and Storage.....	43
Chapter 9 Decals and Warning Labels.....	45
Chapter 10 Specifications	57
10.1 Hydraulic Oil Specifications	60
Chapter 11 Maintenance Schedule	61



This page left blank intentionally

Chapter 1 Safety



Death or severe injuries can be caused if the instructions and safety regulations in this manual are not followed.



Operation of the machine is forbidden, unless:

The safe operation rules of the machine are understood and practiced.

Dangerous conditions are avoided. All safety regulations shall be acknowledged and understood before the next step.

The pre-operation inspection is always completed before operation of the machine.

The function test is always made before operation of the machine.

The workstation is inspected and tested.

The machine is used for its design purposes
The manufacturer's instruction and safety regulations-the safe operation manuals and machine labels, shall be read, comprehended and followed.

The safety regulations for user and the site regulations shall be read, comprehended and followed.

All applicable laws and regulations of the government are read, understood and followed.

The appropriate training on safe operation of machine has been completed.



Classification of hazards

The meanings of symbols, color codes and characters of LGMG North America's products are as follows:

Security warning symbol: are used for warning of potential personal injuries.

Observe all safety instructions below these signs, to avoid situations causing potential personal injury and death.



Red: Signifies dangerous situations. If not avoided, will result in personal death or severe injury.



Orange: Signifies dangerous situations. If not avoided, may result in personal death or severe injury.



Yellow: Signifies dangerous situations. If not avoided, may result in minor or intermediate personal injury.



Blue: Signifies dangerous situations. If not avoided, property loss or damage can occur.

1.1 Description

This machine is a mobile elevating work platform, consisting of a work platform on a scissor mechanism. It is electrically powered and drive power is provided by electric motors.

1.2 Maintenance of Safety Signs and Decals

Replace any missed or damaged safety signs or decals. If necessary, use mild soap and water to clean safety signs. Do not use solvent-based cleaners because they may damage the safety sign material.

1.3 Workstation Safety



This machine is not electrically insulated and does not provide protection from touching or getting close to electrical power lines. Please keep a safe distance from power lines and power equipment according to the applicable laws and regulations. Refer to the following table for safe approach distances for power lines.

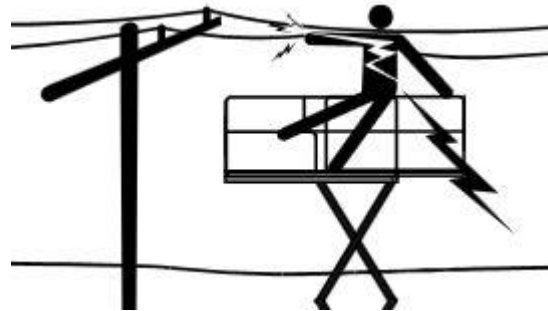

Table 1 Minimum Safe Approach Distance

Voltage	Required Clearance
0 to 50KV	10ft (3.05m)
50KV to 200KV	15ft (4.6m)
200KV to 350KV	20ft (6.10m)
350KV to 500KV	25ft (7.62m)
500KV to 750KV	35ft (10.67m)
750KV to 1000KV	45ft (13.72m)

- Always take into account the influence of strong or gusty winds on the platform and also on the swinging of the electrical power lines.

- Stay away from the machine if it contacts a live electric wire. Do not touch or operate the machine from the ground or the platform before cutting off the power supply.
- Do not operate the machine in inclement weather.
- Do not use the machine as a ground for welding. This could damage electrical components on the machine.
- Do not touch the battery charger when charging the batteries.

 **Tip Over Hazard**

The personnel, equipment, and material on the platform shall not exceed the maximum bearing capacity of the platform and the extending platform. Refer to Chapter 10 – Specifications for model capacities.

- 1) The platform can only be elevated on flat, solid ground.

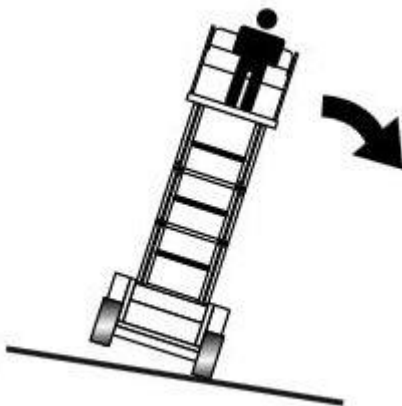

- 2) The maximum elevated drive speed for models AS2632E and AS4046E is 0.5mph (0.8 kph). The maximum elevated drive speed for model SS1432E and SS1932E is 0.31 mph (0.5 kph).
- 3) Do not use the tilt alarm as a level indicator. The tilt alarm only sounds when the machine is severely tilted.
- 4) If the tilt alarm sounds: lower the platform and move the platform to flat, solid ground. If the tilt alarm sounds when elevating the platform, lower the platform immediately.
- 5) If the machine is used outdoors, do not elevate the platform when wind speed is above 28mph (12.5 m/s). If wind speed exceeds the limit after elevating the platform, immediately lower the platform and stop all machine operation.
- 6) The ambient temperature range for use of this machine is -4°F to 104°F (-20°C to 40°C)
- 7) The relative humidity for use of this machine shall be no greater than 90% (at 68°F [20°C]).
- 8) The allowable voltage fluctuation of the machine is ±10%.
- 9) Do not increase the surface area of platform or load. Increasing the exposure area in wind will reduce the stability of machine.

- 10) When the platform is caught, stuck or blocked by a nearby item and is unable to normally move, do not try to release the platform using the platform controller. All personnel must be removed from the platform before releasing the platform using the ground controller.
- 11) Be cautious and lower drive speed when the machine is fully lowered and driving on an uneven road, a gravel road, an unstable or smooth surface, near a hole, or on a slope.
- 12) Do not drive the machine on any uneven or unstable roads or in any other dangerous conditions, when the platform is elevated.
- 13) Do not use the platform to push any item or object.
- 14) Do not use the machine as a crane.
- 15) Do not place, anchor, or suspend any load from any part of the machine.
- 16) Do not push the machine or other items using the platform.
- 17) Do not operate the machine when the chassis tray is pulled out.
- 18) Do not lean the platform against any nearby structure or wall.
- 20) Do not modify or limit the use of the limit switch.
- 21) Do not bind or tie the platform to a nearby structure or wall.
- 22) Do not place the load outside the platform guard rail.
- 23) Do not modify or change the aerial work platform without the written consent of the manufacturer. Installing an additional device used for carrying tools or other materials on the platform, pedal, or guard rail will increase platform weight, platform surface area, and load.
- 24) Do not modify or damage any safety or stability related parts of the machine.
- 25) Do not replace any key stability-related parts with those with different weights or specifications.
- 26) It is forbidden to use a battery weighing less than the original battery. The battery installed on the chassis is used as counterweight and is vital for the stability of machine. Every battery has a different weight (as detailed in the following table).

Table 2 Battery Weights

Model	Battery weight
AS2632E	62lbs (28Kg)
SS1432E	86lbs (39Kg)
SS1932E	
AS4046E	

The minimum weight of battery tray (including the battery) on the chassis varies with the model type as detailed in the following table.

Table 3 Battery Tray Weights

Model	Weight of battery tray and batteries
SS1432E	234lbs(106Kg)
SS1932E	
AS2632E	331lbs(160Kg)
AS4046E	408lbs(185Kg)

- 27) Do not place the steps, ladders, or scaffolding in the platform or lean them against any part of the machine.
- 28) Tools and materials, evenly distributed and able to be safely moved by the operator in the platform, can be carried in the platform only.
- 29) Do not use the machine on a movable surface or vehicle.
- 30) Keep all tires in good condition and appropriately tighten the lug nuts.

Crushing Hazards

- Do not place arms, hands, or fingers in any position where there is a hazard of potential crushing by the machine's scissors.
- When the machine is being driven from the ground using the controller, use good judgment and carefully plan the travel path. Keep a safe distance between the operator, machine and any fixed objects, walls, or buildings.

Hazards When Operating on a Slope

- Do not drive the machine on a slope that exceeds the slope and side slope rating of the machine. The rated value of slope is applicable to a stowed machine. Refer to Chapter 10 – Specifications.

Falling Hazards

- All workers in the platform must use approved safety harnesses and attach the lanyard to the provided anchor points in the platform. Each anchor point is limited to one lanyard.



- Do not climb on or sit on the guard rail of the platform. Firmly stand on the platform floor at all times.

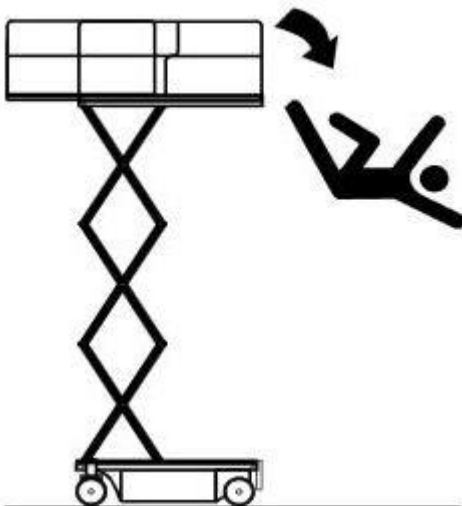

- Do not climb down the platform scissors when the machine is elevated.
- Keep the platform floor free from debris.
- Shut down the platform door before operation.

- Do not operate the machine if the guard rail is not correctly installed.
- Do not enter or exit the platform unless the machine is in the stowed position.

 **Crash Hazards**

- Pay attention to any items or obstacles within the machine's sight line and in any blind spots when starting or running the machine.
- Pay attention to the position of the extending platform when moving the machine.
- Check the workstation to avoid any overhead barriers or other possible hazards in the work site.

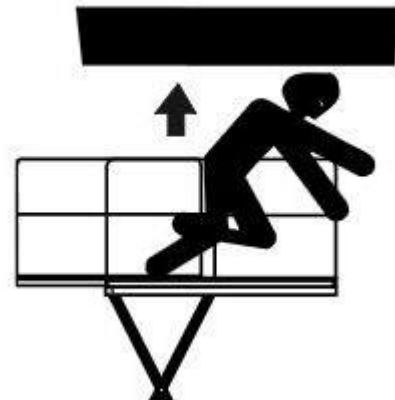

- Pay attention to any crushing hazards when holding the guard rail of the platform.

- The operator must follow the manufacturer's service rules for personal protection equipment, the service rules for the workstation, and the laws and regulations made by the local government.
- Observe and follow the traveling arrow and the turning direction arrows on the platform controller and the platform's label and nameplate.
- Do not operate the machine on the line of any crane or movable overhead machine, unless the crane controller is locked and/or the potential bump prevention measure is taken.
- Dangerous driving or careless operation when running the machine are strictly prohibited.
- The platform can be lowered only when there are no personnel or barriers below the platform.
- Limit travel speed according to ground conditions, traffic, road grade, personnel position, or any other possible bump factors.

**Component Damage Hazards**

- Do not charge the batteries with anything more than a 24V battery charger.
- Do not use the machine as a ground for welding. This could cause damage to the electrical components on the machine.

**Explosion and Fire Hazards**

- Do not operate or charge the machine in a location with a potential for inflammable or explosive gas or particles.

**Machine Damage Hazards**

- Do not use a damaged or malfunctioning machine.
- Make a complete operational and function check before each shift. Attach a tag on a damaged or malfunctioning machine immediately and stop all operation.

- Be sure to perform all maintenance and operation according to the instructions in this manual.
- Be sure to keep all labels and decals at the appropriate locations. Replace any that are not legible.
- Be sure to keep this manual in the manual box of the platform.



Personal Injury Hazards

- Do not operate the machine if it is leaking hydraulic oil. Leaking hydraulic oil under pressure can pierce or burn skin.
- Severe injury may result if any component below the cover is touched by mistake. Only trained technicians can perform maintenance to the components under the cover. The operator shall only perform maintenance before the pre-operation inspection. Be sure to keep all compartments closed and locked during operation of the machine.

1.4 Battery Safety



Combustion hazards

- The battery contains acid. Wear protective clothing and safety goggles when performing maintenance on the battery.
- Take measures to prevent acid from overflowing out of the battery or being touched. Neutralize the overflowed acid material from the battery with soda and water.



Explosion danger

- Keep the battery away from any sparks or open flames. The battery can release an explosive gas.
- Do not touch the battery terminal or the cables with any tool that may cause a spark.
- When the vehicle stops for a long time, it is necessary to turn off the main power switch.

**Component damage hazard**

Do not charge the battery with more than a 24V battery charger.

**Electrocution/Burn hazards**

- **The battery charger can be connected to the grounded AC three-wire power socket.**
- **On a daily basis, check to see if the wire cable, electric cable and wiring are damaged. Replace the damaged items before the operation.**
- **Take measures to prevent electric shock from touching the battery terminals. When working on the electrical circuits, remove all jewelry and metallic objects. The battery charger can be connected to the grounded AC three-wire power socket.**

1.5 Lock After Each Use

- 1) Choose a safe parking position which is solid and horizontal ground where there are no barriers or heavy traffic.
- 2) Lower the platform.
- 3) Rotate the key switch to the “OFF” position and pull out the key, to avoid unauthorized use.
- 4) Chock the wheels.
- 5) Charge the battery.
- 6) Disconnect and remove the platform control box. Store in a safe location.



This page left blank intentionally

Chapter 2 Machine Nomenclature

 Notice: This drawing shows an AS1932E, but the nomenclature is common for all other models.

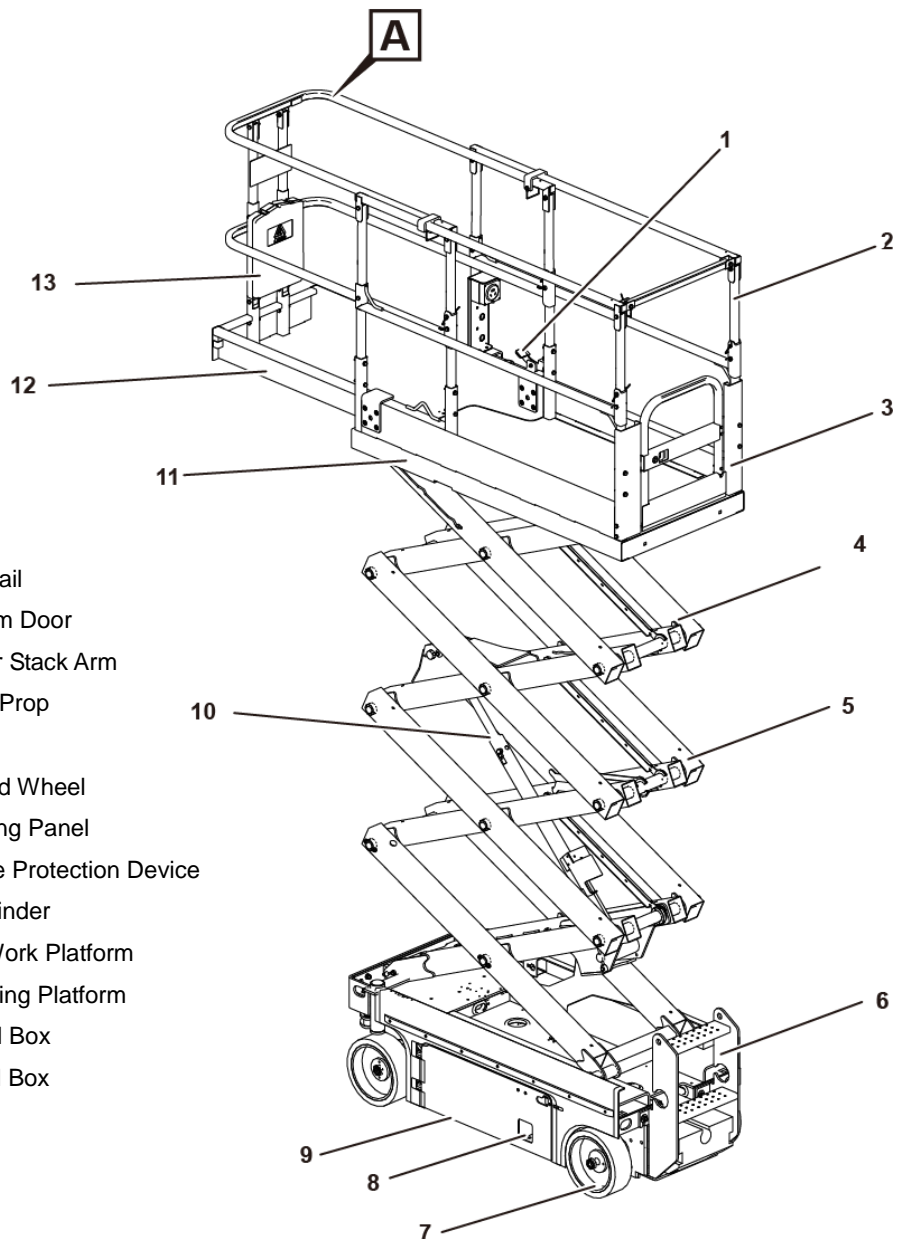
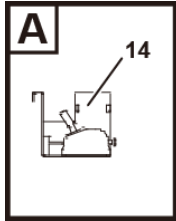

- 1. Pedal
- 2. Guardrail
- 3. Platform Door
- 4. Scissor Stack Arm
- 5. Safety Prop
- 6. Ladder
- 7. Tire and Wheel
- 8. Charging Panel
- 9. Pothole Protection Device
- 10. Lift Cylinder
- 11. Main Work Platform
- 12. Extending Platform
- 13. Manual Box
- 14. Control Box



This page left blank intentionally

Chapter 3 Controls

3.1 Ground Controls

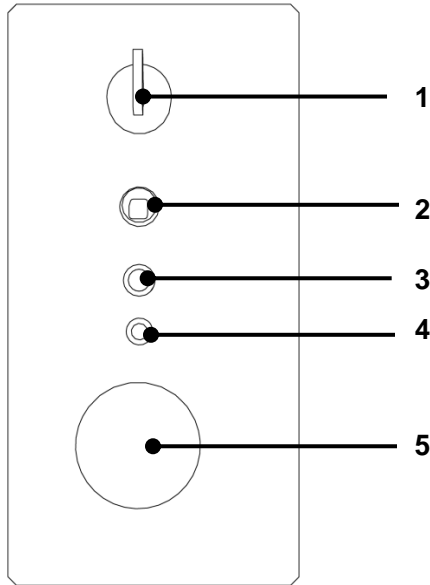

- 1. Key Switch
- 2. Platform Lift Switch
- 3. Auto reset fuse (7A)
- 4. Overload indicator lamp
- 5. Emergency stop switch

3.1.1 Key Switch

The three-position key switch controls the power supply for the machine. When the switch is set to the left, the platform operation mode will be enabled; when the switch is set to the right position, the chassis operation mode will be enabled; when the switch is set to the center position, the power to the machine will be off.



The key can be inserted or removed only when the switch is in the center position. Some machines are equipped with optional switches that allow the keys to be inserted or removed at all three positions.

3.1.2 Emergency Stop Switch

The power supply to the machine is disconnected when the emergency stop switch is pressed.



An emergency stop switch is installed on both the chassis and the platform controller. The two switches operate together in series. Normal operation can be performed when both switches are pulled out. The power supply will be cut off when either emergency stop switch is pressed.

3.1.3 Platform Lift Switch

The platform Lift Switch is only used to control the lifting or lowering of platform.

3.2 Platform Controls

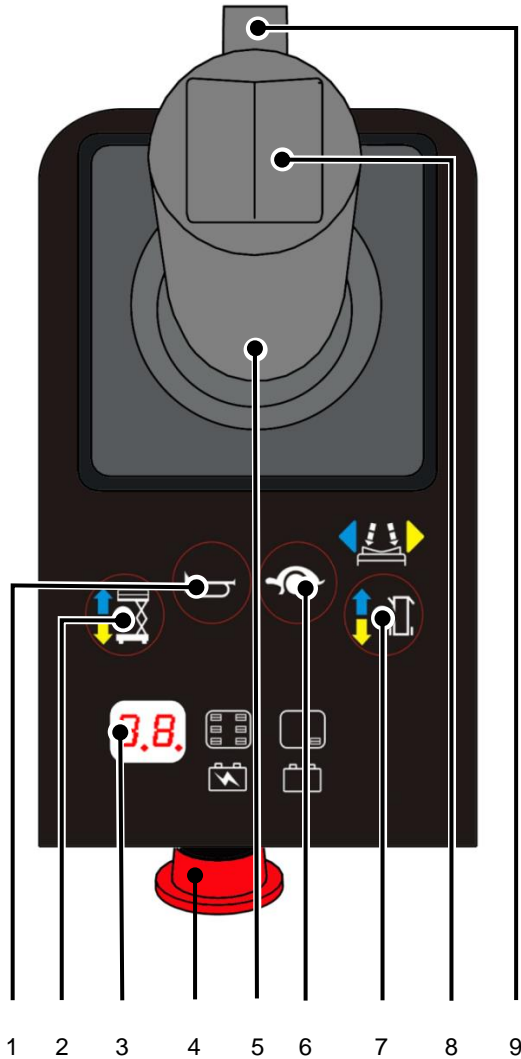

- 1. Horn Button
- 2. Lift Switch
- 3. Display
- 4. Emergency Stop Switch
- 5. Control Lever
- 6. Drive Speed Button
- 7. Drive Function Button
- 8. Steer Switch
- 9. Enabling Switch

3.2.1 Horn Button

The horn will sound when this button is pressed, and will stop when the button is released.

3.2.2 Lift Switch

Pressing this switch activates the lift function for the platform.

3.2.3 Display

The Display shows Diagnostic Fault Codes and when charging the batteries, displays charging status.

Table 4-Data on the Display

Operating step	Displayed data
Power on but no moving	Battery capacity
Move forward or backward	Battery capacity
Lift up the platform	Battery capacity
Lower the platform	Battery capacity
A fault occurs	Error code
Chassis control mode	CH

3.2.4 Emergency Stop Switch

The power supply to the machine is disconnected when the emergency stop switch is pressed.



Notice

An emergency stop switch is installed on both the chassis and the platform controller. The switches operate together in series. Operation can be performed when both switches are pulled out. The power supply will be cut off when either emergency stop switch is pressed.

3.2.5 Drive/Lift Control Lever

Drive function:

After the enabling switch is pressed, the machine will move to the direction (front) indicated by the blue arrow when the control lever is moved to the direction indicated by the blue arrow, or to the direction (back) indicated by the yellow arrow when the control lever is moved to the direction indicated by the yellow arrow.

Lift function:

After the enabling switch is pressed, the platform will raise when the control lever is moved to the direction indicated by the blue arrow, or lower when the control lever is moved to the direction indicated by the yellow arrow.



When the platform is lowering, the lowering alarm will beep.



If using emergency lowering, the alarm will not beep.

3.2.6 Drive Speed Button

Pressing this button will select the slow or fast drive function.

3.2.7 Drive Function Button

Pressing this button activates the drive function.

3.2.8 Steer Switch

After the drive function button and the enabling switch on the lever are pressed, the steer switch can be used to control the steering direction of the machine.

3.2.9 Enabling Switch

The driving, steering, lifting or lowering function can be activated only when the enabling switch on the lever is pressed.



This page left blank intentionally

Chapter 4 Pre-Operation Inspection



WARNING

Operation of this machine is forbidden, unless the safe operation principles of the machine are understood and practiced.

- All dangerous conditions are avoided.
- The pre-operation inspection is always performed.



Notice

Ensure the workstation inspection is fully understood before proceeding to the next step.

- The workstation is inspected and checked.
- The function test is always made before operation.
- The machine is used for its designed purpose.

4.1 Basic Principles

- 1) The pre-operation inspection and routine maintenance are the responsibilities of the operator.

- 2) The pre-operation inspection is a visual process, which shall be performed daily by the operator before each work shift. The purpose of the inspection is to check the machine for any significant problems before performing the Function Test.
- 3) The pre-operation inspection can also be used for confirming if routine maintenance is required. The operator shall only perform routine maintenance as specified in this manual.
- 4) Check the list in the next page and check every item.
- 5) If any damage is found or any un-permitted change different to the delivery status is found, tag the controls and stop operation of the machine.
- 6) Only qualified maintenance technicians are permitted to repair the machine as per LGMG North America. After the required maintenance has been performed, the operator must carry out the pre-operation inspection again before the function test.

4.2 Pre-Operation Inspection

- 1) Ensure the manual is complete and legible. Keep it in the manual box on the platform.
- 2) Keep all labels clear and readable and place them appropriately. Go through the label.
- 3) Check for any hydraulic oil leakage and

- proper oil level. Go through the label.
- 4) Check for any battery fluid leakage and if the liquid level is suitable. Add distilled water, if required.
 - 5) Inspect the entire machine for:
 - a) Cracks in welds or structural components.
 - b) Machine pitting or damage.
 - c) All structural members and other key components have no missing parts, related fasteners and pins are in the correct position, and properly tightened.
 - d) Install the guard rail, place the guard rail pin in place, and tighten the retaining bolts.
 - 6) Check the following components for damage, proper installation, and any missing parts or unauthorized changes to components:
 - a) Battery pack and connections.
 - b) Electric element, wiring and cable.
 - c) Nuts, bolts, and all other fasteners.
 - d) Hydraulic hoses, connectors, cylinders, and valves.
 - e) All Indicator lamps and alarms.
 - f) Safety props.
 - g) Pothole guards.
 - h) Platform overload components (if equipped).
 - i) Scissor arm pins and fasteners.
 - j) Limit switches, alarms, and horn.
 - k) Drive motors.
 - l) Tires and wheels.
 - m) Slide blocks and liners.
 - n) Brake release components.
 - o) Ground straps.
 - p) Platform entry gate.
 - q) Platform control box.
 - r) Extending platform deck.
 - s) Keep the chassis battery tray and oil pump tray closed and locked. Engage the battery disconnect switch.



If the platform must be elevated to inspect any machine components, keep the safety prop in the correct position. Refer to Chapter 7 – Operating Instructions.

Chapter 5 Workstation Inspection

Warning

Operation is forbidden unless the following safe operating principles of the machine are understood and performed.

- 1) All dangerous work site conditions are avoided.
- 2) Pre-Operation Inspection has been completed.
- 3) The workstation has been inspected.

Notice

The workstation inspection must be performed and proper operating procedures understood before the next step.

- 4) The function test has been performed.
- 5) The machine is used as described in this manual.

5.1 General Information

- 1) Using the Workstation Inspection procedures, the operator can determine if the safe operation of machine is possible from the workstation. The operator shall carry out this process before operating the machine from the workstation.

- 2) Understanding the hazards of the workstation are the responsibilities of the operator. Avoid these hazards while moving, delivering, or operating the machine.

5.2 Workstation Inspection

Be aware of the following hazards:

- 1) Sudden slopes, holes, or dips in the traveling surface.
- 2) Bumps, ground barriers, or debris on the ground.
- 3) Inclined plane.
- 4) Infirm or unsteady ground surface.
- 5) Overhead barriers and high-voltage power lines.
- 6) Dangerous location
- 7) Supporting surface unable to bear the load of the machine.
- 8) Wind and inclement weather.
- 9) Unauthorized personnel.
- 10) Other possible unsafe conditions.



This page left blank intentionally

Chapter 6 Function Test



Operation is forbidden unless the following safe operating principles of the machine are understood and performed.

- 1) All dangerous work site conditions are avoided.
- 2) Pre-Operation Inspection has been completed.
- 3) The workstation has been inspected.
- 4) The function test has been performed prior to any operation.



The function test must be performed and proper operating procedures understood before the next step.

- 5) The machine is used as described in this manual.

6.1 General Information

- 1) The purpose of the Function Test is to identify potential component failure before operating the machine.
- 2) The operator must test all machine functions as outlined in this section.

- 3) Do not use a damaged or malfunctioning machine. Tag out the control boxes and do not use the machine until repairs have been made.
- 4) Only qualified maintenance technicians are permitted to repair the machine as per the regulations of the manufacturer.
- 5) After repairs or maintenance have been performed, the operator must perform out the Pre-Operation inspection and Functional Test again before operating the machine.

6.2 Function Test

- 1) Carry out the function test on a firm and level surface with no barriers or obstructions.
- 2) Ensure the battery pack is connected.

6.3 Tests from the Ground Controls

- 1) Pull out the red emergency stop buttons on the platform controller and the ground controller to the ON position.
- 2) Turn the key switch to the ground controller position.
- 3) Observe the LED display on the platform controller for the proper reading.

6.4 Test the Emergency Stop Switch

- 1) Push the emergency stop switch on the ground control station in to the OFF position. Result: All Functions should be disabled.
- 2) Pull the emergency stop switch out to the ON position.

6.5 Test of Lifting/Lowering Function



The alarm system will control the buzzer to output the alarms with different frequencies. The lowering alarm will sound 60 times per minute. If the pothole guards fail to deploy and set, the buzzer will sound 180 times per minute. The buzzer will sound 180 times per minute for any overload.

- 1) Position the key switch to the platform controller or the OFF position.
- 2) Push up and hold the platform lift control lever. Result: The platform fails to elevate.
- 3) Position the key switch to the ground control position.
- 4) Push up and hold the platform lift control switch. Result: The platform will elevate.
- 5) Push down and hold the platform lift switch. Results: The platform will lower. When the platform is lowering, the alarm shall sound.

- 6) Push down and hold the platform lift switch again. Result: The platform shall descend to the lowest position. When the platform descends, the alarm will sound.

6.6 Emergency Lowering Function Test

- 1) Push up the platform lift switch to elevate the platform approximately 24 in (60cm).
- 2) Pull out the emergency lowering control button at the right front part of the machine. Result: The platform shall descend. The lowering alarm shall not sound.
- 3) Switch the key switch to the platform controller.

6.7 Platform Controller Test

- 1) Push the ground Emergency Stop Switch in to the OFF position. Result: All functions will not operate.
- 2) Pull the Emergency Stop Switch out to the "ON" position. Result: The LED display will light up.

6.8 Horn Test

- 1) Pull the Emergency Stop Switch out to the "ON" position.
- 2) Push the Enable Switch and activate a function.
- 3) Press the horn button. Result: The horn will sound.

6.9 Lift Function and Function Enable Switch Test

- 1) Do not press the enable switch on the control handle.
- 2) Slowly move the control handle as per the blue arrows and then move it as per the yellow arrows. Result: All lift functions shall not be operational.
- 3) Press the lift function selector button.
- 4) Press the enable switch on the control handle.
- 5) Slowly move the control handle as per the blue arrows. Result: The platform shall elevate and the pothole guards shall be deployed.
- 6) Release the platform control handle. Result: The platform will stop elevating.
- 7) Press the enable switch. Slowly move the control handle as per the yellow arrows. Result: The platform will lower. When the platform lowers, the lowering alarm will sound.

6.10 Steering Test



Face the end of the machine that steers when testing the steering and driving functions.

- 1) Press the drive function selector switch. The drive function indicator will light.
- 2) Press the enable switch on the control handle.
- 3) Press the rocker switch on top of control handle according to the direction indicated by leftward arrows on the control panel. Result: The front wheels shall move as per the direction indicated by the leftward arrows on the chassis
- 4) Press the rocker switch on top of the control handle according to the direction indicated by rightward arrows on the control panel. Result: The front wheels shall move as per the direction indicated by the rightward arrows the chassis.

6.11 Driving and Braking Function Test

- 1) Press the enable switch on the control handle.
- 2) Slowly push the control handle as per the direction of the forward arrows on the control panel until the machine is moving and return the handle to the center position. Result: The machine shall move forward and then stop.
- 3) Slowly move the control handle as per the direction of the backward arrows on the control panel until the machine is moving and return the handle to the center position. Result: The machine shall move backward and then stop.



Notice

The brake must be able to stop the machine on any grade.

6.12 Driving Function Test

- 1) Press the lift function button; the indicator lamp will light up. Press and hold the enable switch to lift the platform to the height called out in the following table. Result: The pothole guards will be deployed.

Table 5 - Pothole Deployment Height When Driving

Model	Height
AS2632E	6.9ft (2.1m)
AS4046E	
SS1432E	6.56ft (2m)
SS1932E	7.97ft (2.43m)

- 2) Press the drive function selector button. The indicator light will light up.
- 3) Press the enable switch on the control handle and slowly move the control handle fully forward. Result: The drive speed of the platform will not be greater than 0.5mph (0.8km/h) when the platform is elevated. On model SS1230E/SS1432E/SS1932E, the driving speed of the platform will not be greater than 0.3mph (0.5km/h) when the platform is elevated. If the elevated driving speed of the platform exceeds these limits, immediately tag out the controls and stop operation until repairs are made.

6.13 Operation of Tilt Sensor Test



Notice

This test is performed with the platform controller from the ground. Do not stand in the platform.

- 1) Completely lower the platform.
- 2) Drive two wheels on the same side of the machine up on a 1.37x7.9in (3.5x20cm) block.
- 3) Lift up the platform to a height listed in the following table. Result: The platform will stop moving and the tilt alarm will sound at a rate of 120 times per minute.

Table 6- Drive Cutout Height When Tilted

Model	Height
SS1432E	6.56ft (2m)
AS4046E	6.9ft (2.1m)
AS2632E	
SS1932E	8.53ft (2.6m)

- 4) Slowly move the control handle to operate drive forward and then driver reverse. Result: The drive function will be disabled in either direction.
- 5) Lower the platform and drive the machine off of the blocks.

6.14 Pothole Guard Test



When the platform is elevated, the pothole guards will be automatically deployed. The pothole guards initialize another limit switch to enable the continuous drive/steer operation of machine. If the pothole guards fails to be deployed, the alarm will sound and the machine will stop all drive and steer functions.

- 1) Lift the platform. Result: When the platform elevates a given height (as shown in the following table), the pothole guards shall be deployed.

Table 7 - Pothole Deployment Height When Lifting

Model	Height
AS2632E	6.2ft (1.9m)
AS4046E	
SS1432E	6.56ft (2m)
SS1932E	7.97ft (2.43m)

- 2) Press one side of the pothole guard and then other side. Result: The pothole guard will not move.
- 3) Lower the platform. Result: The pothole guard will be returned to the stowed position.
- 4) Place blocks under the pothole guards (1.38in×7.9in [3.5cm×20cm] wood block or a

similar material) and elevate the platform.
 Result: When the platform elevates a given height (as shown in the following table), the alarm will sound. The drive function will be disabled.

Model	Height
SS1432E	6.56ft (2m)
AS2632E	6.9ft (2.1m)
AS4046E	
SS1932E	8.53ft (2.6m)

- 5) Lower the platform and remove the blocks.

Chapter 7 Operating Instructions

Warning:

Operation is forbidden unless the following safe operating principles of the machine are understood and performed.

- 1) The dangerous conditions are avoided.
- 2) The pre-operation inspection is always made.
- 3) The workstation is checked.
- 4) The function test is always made before the use.
- 5) The machine is used for its design purposes.

7.1 General Information

- 1) This machine is an electrically powered mobile elevating work platform, consisting of a work platform on an elevating scissors mechanism. The vibration produced by the running machine causes no hazards to the operators on the work platform. This machine can be used for carrying the workers and their tools to the specified height above the ground and also for reaching the workstation above the machine or equipment.
- 2) Detailed operating instructions for all functions are outlined in this Operation section. It is the operator's responsibility to follow all safety regulations and descriptions in this operation and maintenance manual.

- 3) It is prohibited to use the machine for any purpose other than carrying the staff, equipment, tool and material to the overhead workstation.
- 4) Only trained and authorized personnel can operate this machine. Each operator shall perform the pre-operation inspection, function test and workstation inspection before running the machine.

7.2 Emergency Stop

- 1) Push the emergency stop switch on the ground or platform controller to the OFF position to disable all functions.
- 2) The recovery of any operation function must be done by pressing the emergency stop switch.

7.3 Emergency Lowering

Pull the emergency lowering control button outward.

7.4 Operation from the Ground Controls

- 1) Turn the key switch to the ground position.
- 2) Pull the emergency stop switch on the ground and the platform to the ON position.
- 3) Ensure the battery tray is connected before running the machine.

7.5 Platform Positioning

Move the platform lifting and lowering switch according to the mark on the control panel.

The driving and turning functions are unavailable from the ground controller.

7.6 Operation from the Platform Controls

- 1) Turn the key switch to the platform control position.
- 2) Pull the emergency stop switch out on both ground controls and the platform controls to the ON position.
- 3) Ensure the battery tray is connected before running the machine

7.7 Platform Positioning

- 1) Press the lift function selector switch.
- 2) Press the enable switch on the control handle.
- 3) Move the handle forward to elevate and rearward to lower.

7.8 Steering

- 1) Press the drive function selector switch.
- 2) Press the enable key on the control handle.
- 3) Turn the wheels in the desired direction using the rocker switch on the top of control handle.

7.9 Drive

- 1) Press the drive function selector switch.
- 2) Hold the enable switch on the control handle.
- 3) To increase speed, slowly move the control handle away from the centered position. To decrease speed, slowly return the control handle to the center position. To stop, fully return the handle to the center position or release the enable switch.
- 4) Coordinate machine drive direction with the direction arrows on the platform controller and the platform.
- 5) When the platform is elevated, the drive speed of the machine is reduced.
- 6) The charge status of the battery pack will affect machine performance.
- 7) When the battery level indicator lamp flashes, driving speed and functional speed of machine will be reduced.





7.10 Drive Speed Option

The drive controller can be operated at two different drive speeds. When the drive speed selector switch indicator lights up, slow driving speed mode is enabled. When the driving speed selector switch lamp goes out, the high speed drive mode is enabled. Press the driving speed selector switch to select the desired driving speed.

7.11 Driving the Machine from the Ground

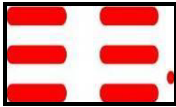
- 1) Keep a safe distance between the operator, machine, and any stationary object.
- 2) Be cautious and aware of the driving direction of machine when using the controller from the ground.
- 3) Identify the battery level with the LED display.

Table 8 - Battery Level as Shown on LED Display

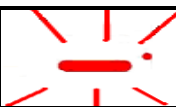
Platform Display	Battery Percentage (%)	Description
	90-100	The battery capacity is full
	70	Percentage of remaining battery capacity
	50	Percentage of remaining battery capacity
	30	Percentage of remaining battery capacity
	20	The battery must be charged
	10	The battery capacity is very low



When the battery capacity is very low ($\leq 10\%$), the machine will change to low speed mode automatically.

7.12 Using the Safety Prop

- 1) Elevate the platform a specified height above the ground (for elevation height, refer to the following table).

Model	Height
SS1432E	7.9ft (2.4m)
SS1932E	9.09ft (2.77m)
AS2632E	6.89ft (2.1m)
AS4046E	13.1ft (4m)

- 2) Lift the safety prop, move it to the center of the scissor cross tube and rotate it upward until it is vertical.
- 3) Lower the platform height until the safety prop completely contacts the shaft tube. Keep the platform away from the movable parts during the lowering process.



Do not carry any load in the platform when the safety prop is being used. No long time (8 hours) to use safety prop in empty state.

7.13 How to Stow the Guardrail

On models SS1432E/ SS1932E, the platform guardrail system consists of a folding guardrail on an extended platform and a folding guardrail on

the main platform.

- 1) Fully lower the platform and lock it into the extended platform.
- 2) Remove the platform controller.
- 3) Remove the two retaining pins at the front of the extended platform from the inside of the main platform.
- 4) Push the front guardrail of the extended platform inward. Do not place your hands in places where there may be a pinch point.
- 5) Remove the retaining pin of the left guardrail of the extended platform and fold the left guardrail of the extended platform inward. Do not place your hands in places where there may be a pinch point.
- 6) Remove the retaining pin of the right guardrail of the extended platform and fold the right guardrail of the extended platform inward. Do not place your hands in places where there may be a pinch point.
- 7) Install the four retaining pins which were removed back to the guardrail on each side.
- 8) Remove the two retaining pins on the upper part of the door.
- 9) Push the door guardrail from the ladder or the ground inward. Do not place your hands in places where there may be a pinch point.
- 10) Remove a retaining pin from the left guardrail of the main platform.
- 11) Push the left guardrail of the main platform from the ladder or the ground inward. Do not place your hands in places where there may be a pinch point.
- 12) Remove a retaining pin from the right guardrail of the main platform.

- 13) Push the right guardrail of the main platform from the ladder or the ground inward. Do not place your hands in places where there may be a pinch point.
- 14) Install the two retaining pins which were removed back to the guardrail on each side.

The model AS2632E platform guardrail system consists of folding guardrails of extending platform and main platform.

- 1) Completely lower the platform and lock the extending platform.
- 2) Remove the platform controller.
- 3) Remove two retaining pins in the front of extending platform inside the platform.
- 4) Tilt the front guardrail of extending platform inward. Do not place your hands in places where there may be a pinch point.
- 5) Install the two removed retaining pins on the guardrail bracket on each side.
- 6) Tilt the left guardrail of the extending platform inward. Do not place your hands in places where there may be a pinch point.
- 7) Tilt the right guardrail of the extending platform inward. Do not place your hands in places where there may be a pinch point.
- 8) Remove the retaining pins at the rear of main platform.
- 9) Tilt the rear guardrail forward. Do not place your hands in places where there may be a pinch point.
- 10) Install the removed retaining pins onto the

guardrail bracket on every side.

- 11) Fold the left and right guardrails of main platform on the ladder or ground. Do not place your hands in places where there may be a pinch point.

On model AS4046E, the platform guardrail systems consist of folding guardrails of extending platform and main platform. The platform is classified into the revolving gantry platform and the derrick drilling platform according to the platform entrance structure. The folding methods of the guardrails on the two kinds of platforms are different. The folding steps of revolving gantry platform are described below:

- 1) Completely lower the platform and lock the extending platform.
- 2) Remove the platform controller.
- 3) Remove two retaining pins in the front of extending platform inside the platform.
- 4) Tilt the front guardrail of the extending platform inward. Do not place your hands in places where there may be a pinch point.
- 5) Install the two removed retaining pins on the guardrail bracket every side.
- 6) Tilt the left guardrail of the extending platform inward. Do not place your hands in places where there may be a pinch point.
- 7) Tilt the right guardrail of the extending platform inward. Do not place your hands in places where there may be a pinch point.
- 8) Remove the retaining pins at the rear of right guardrail of main platform.

- 9) Tilt the rear right guardrail forward. Do not place your hands in places where there may be a pinch point.
- 10) Install the removed retaining pins onto the right guardrail bracket.
- 11) Fold the left and right guardrails of main platform on the ladder or ground. Do not place your hands in places where there may be a pinch point.
- 12) Remove the retaining pins at the rear of left guardrail of main platform.
- 13) Tilt the rear left guardrail forward. Do not place your hands in places where there may be a pinch point.
- 14) Install the removed retaining pins onto the left guardrail bracket.
- 15) Fold the left guardrail of the main platform. Do not place your hands in places where there may be a pinch point.

7.14 How to Erect the Guardrail

To erect the guardrails, reverse the sequence outlined in How to Stow the Guardrail.

7.15 Extending and Retracting the Extending Platform Deck

- 1) Step on the positioning pedal on the extending platform.
- 2) Push the guardrail of the extending platform to extend the platform to the desired position.



Do not stand on the extending platform deck while extending it.

7.16 Error Codes



Notice

When an error code is present, the code will flash once per second on the screens of the ECU and PCU.

Table 9 - Error Codes

Display	Description	Response
01	System initialization error	Stop all actions
02	System communication error	Stop all actions
03	No machine code is set during the first use	Stop all actions
04	The set code is invalid	Stop all actions
06	Prompt of successful release of the remote parameter	Display alarm only
07	Secondary lock alarm	Disable lifting and running
08	Prompt of successful release of weight calibration data	Display alarm only
12	Chassis lifting or lowering button opening error during start	Stop all chassis controls
18	Pothole protection error	Stop lifting and running
31	Pressure sensor error	Stop all actions
32	Angle sensor error	Stop all actions
33	1412 light load mode data calibration error	Disable lifting with handle
35	Calibration data error	Display alarm only
36	Low battery alarm	
38	Activated overload function and uncompleted weight calibration error	Disable lifting with handle
39	The battery level switch detects the low level of the battery.	Display alarm only
40	Alarm of failed ECU and GPS handshake	Running but no lifting
41	Lock vehicle status through platform (only applicable to the ECU with the GPS function)	Running but no lifting
42	Platform left turn button pressing error during start	Display alarm only
43	Platform right turn button pressing error during start	Display alarm only
46	Platform handle enable switch button pressing error during start	Stop platform control
47	"The platform handle is not in the middle position" error during start	The speed is reduced to the speed after lifting
52	Forward coil error	Stop lifting and running

53	Backward coil error	Stop lifting and running
54	Lifting error of lifting coil	Stop lifting and running
55	Lifting error of lowering coil	Stop lifting and running
56	Right turn coil error	Stop lifting and running
57	Left turn coil error	Stop lifting and running
58	Brake coil error (because the brake coil is optional, this function is temporarily shielded)	Stop lifting and running
61	Electric drive motor controller current sensor error (overheating of running or lifting motor)	Disable action
62	Motor controller hardware damage error	Disable action
63	Motor controller motor output error	Disable action
64	Motor controller SRO error	Disable action
65	Motor controller throttle valve error	Disable action
66	Motor controller emergency reverse error	
67	Motor controller HPD error	
68	Low voltage alarm	Stop all actions
69	High neutral current (MC is detecting current in the motor, but there shall be no current in this case)	Disable action
70	The steering input is beyond the range (the improper voltage is in the steering input)	
71	Motor controller main contactor error	Disable action
72	Motor controller overvoltage error	Disable action
73	Motor controller heat reduction error	Disable action
74	Motor controller motor error	Disable running
75	Motor controller pump motor error	Disable lifting
76	Motor controller left drive motor error	Disable running
77	Motor controller right drive motor error	Disable running
78	Pump motor short circuit error	Disable action
79	Left drive motor short circuit error	Disable running
80	Alarm of exceeding 80% load	Alarm only
81	Right drive motor short circuit error	Disable running
82	Right brake coil error	Disable action

83	Left brake coil error	Disable action
90	Alarm of exceeding 90% load	Alarm only
99	Alarm of exceeding 99% load	Alarm only
OL	Platform overload alarm	Stop all actions
LL	"The machine tilts over the safety limit" error	Stop lifting and running

Table 10 - Troubleshooting Guide

Display	Description
01	System initialization error: The ECU may have fault, replace the ECU.
02	System communication error: Check connection between the communication line and other cables. If fault still exists, please replace the PCU or the ECU.
03	Invalid option setting error: Set proper options for the machine
04	The selected machine code is not within the application range, make selection again based on the model
06	Prompt of successful release of the parameter: Restart it
08	Prompt of successful release of calibration data: Restart it
12	Chassis lifting or lowering button opening error during start: Check the wiring of the toggle switch or check whether the toggle switch is jammed.
18	Pothole protection error: Check whether the pothole protection is activated, and check the pothole protection limit switch. Check the wiring of the switch, lower limit switch and wiring.
31	Pressure sensor error: Check the sensor wiring and the sensor. Check to confirm that the correct machine option with overload detection is selected.
32	Angle sensor error: Check the sensor wiring and the sensor. Check to confirm that the correct machine option with overload detection is selected.
33	1412 light load mode unsuccessful overload weight function data calibration error: Carry out weight calibration again.
38	Error of unsuccessful overload weight function calibration: Carry out weight calibration again.
39	Too low level of the battery: Check the battery level and fill the electrolyte if liquid level is too low. Check whether the liquid level switch is installed correctly.
40	GPS reconnection error: Check connection status
41	Release unlocking instruction through platform (only applicable to the ECU with the GPS function)
42	Platform left turn button pressing error during start: Ensure that buttons on the handle are not pressed. If not, consider replacing the handle or the PCU.
43	Platform right turn button pressing error during start: Ensure that buttons on the handle are not pressed. If not, consider replacing the handle or the PCU.
46	Platform handle enable switch button pressing error during start: Ensure that the enable switch on the handle is not pressed. If not, consider replacing the handle or the PCU.
47	"The platform handle is not in the middle position" error during start: Confirm that the handle is in the middle position, and check the middle position parameter setting. If normal, consider replacing the handle or the PCU.
52	Forward coil error: Check the connection of the coil and confirm that it is normal. If normal, check the coil for short circuit or open circuit.

53	Backward coil error: Check the connection of the coil and confirm that it is normal. If normal, check the coil for short circuit or open circuit.
54	Lifting error of lifting coil: Check the connection of the coil and confirm that it is normal. If normal, check the coil for short circuit or open circuit.
55	Lifting error of lowering coil: Check the connection of the coil and confirm that it is normal. If normal, check the coil for short circuit or open circuit.
56	Right turn coil error: Check the connection of the coil and confirm that it is normal. If normal, check the coil for short circuit or open circuit.
57	Left turn coil error: Check the connection of the coil and confirm that it is normal. If normal, check the coil for short circuit or open circuit.
58	Brake coil error: Check the connection of the coil and confirm that it is normal. If normal, check the coil for short circuit or open circuit.
61	Cool down the machine, and check the wiring. If the wiring is OK, replace the motor controller
62	Restart the machine, if fault exists, check the root cause; if fault still exists, replace the motor controller
63	Check the wiring, and then restart it, and replace the motor controller if necessary
64	Check whether the motor parameter enable delay is too short, and confirm that the parameter is correct
65	Check the wiring, and ensure that the correct throttle type is selected in the motor controller
66	Ensure that the emergency reverse check parameter in the motor controller is set to off
67	The motor enable delay may be too short, and confirm that parameter of other motor controllers is correct
68	Low voltage error: Check the battery voltage and charge if necessary. Check connection between the battery and the switch, reinforce or clean it. Check whether the voltage of the PCU and the ECU is normal.
69	MC is detecting current in the motor, but there shall be no current in this case. MC thinks that the brake is turned on
70	Adjust the ZAPI and/or check the toggle voltage due to loose wiring
71	Check the wiring of the main contactor, and replace the contactor or the motor controller if necessary
72	Check the battery voltage, check if it is charging. If the fault still exists, try to replace the motor controller
73	Cool down the restart machine or replace the motor controller
74	Check the wiring of the motor or replace the motor controller
75	Check the wiring of the pump motor, restart the machine or replace the motor controller
76	Check the wiring of the left drive motor, restart the machine or replace the motor controller
77	Check the wiring of the motor, restart the machine or replace the motor controller
78	Check the wiring of the pump motor, restart the machine or replace the motor controller
79	Check the motor connection and ensure that they are tightened, and check the motor for short circuit
80	Alarm of exceeding 80% load: As the platform is close to the load limit, it is not recommended to increase the load.
81	Check the motor connection and ensure that they are tightened, and check the motor for short circuit
82	Check the connection of the coil terminal and ensure that they are tightened, and check whether the coil is connected properly
83	Check the connection of the coil terminal and ensure that they are tightened, and check whether the coil is connected properly
90	Alarm of exceeding 90% load: As the platform is close to the load limit, it is not recommended to increase the load.

99	Alarm of exceeding 99% load: As the platform has reached the load limit, do not to increase the load.
OL	Platform overload alarm: Remove excessive loads immediately.
LL	“The machine tilts over the safety limit” error: If the machine tilts, try to make it recover horizontal status. If the machine is horizontal, check the wiring of the level sensor or the sensor.

Historical error status

- 1) The controller can display the latest 10 error alarm codes. Press the right turn key on top of handle and hold it for 10 seconds (do not press the enable switch of the handle) to log in the historical error status.
- 2) Press the left turn switch to view the previous error code until reaching the first one. Press the right turn switch, to view the historical error code in the reverse sequence until reaching the latest one. For error codes, please refer to the table above.
- 3) Push the enable switch on the handle to recover the normal operation status.



This page left blank intentionally

Chapter 8 Transport and Lifting Instructions



Obey these instructions.

- When lifting the machine with a crane, ensure the crane has the proper capacity and rigging to handle the weight of the machine.
- Only qualified personnel are allowed to load and unload the machine onto a truck for transport.
- The hauling vehicle must be parked on firm, level ground.
- When loading the machine, be sure to chock the wheels of the hauling vehicle to ensure it won't move.
- Ensure vehicle capacity, load surface, and tie down equipment is adequate for bearing the weight of the machine. Refer to the nameplate on the machine for gross weight.
- Be sure to load the machine on a flat, level surface and chock the wheels before releasing the brake.
- Do not drive the machine when traveling up and down a slope or when driving on a slope exceeding the rated gradeability for the machine. For driving on a slope, refer to Chapter 7 – Operating Instructions. If the loading ramp of the hauling vehicle exceeds the maximum rated travel grade of the

machine, load and unload the machine with a winch as per the instruction for brake releasing operation.

8.1 Releasing the Brake

- 1) Chock the wheels to prevent the machine from rolling.
- 2) Make sure all lifting devices are properly fastened at the designated tie down/lifting points on the chassis, and there are no obstacles in the way.
- 3) Press the brake release button to release the brake. Re-press the brake release button to brake the machine after moving. (AS series models only)

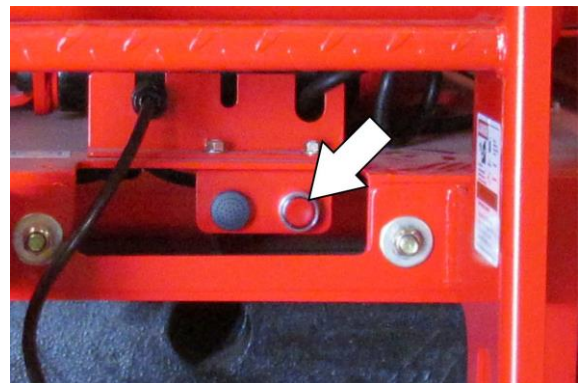

- 4) If system voltage is lower than 10v, operate the drive motor according to the following procedure.

① Unscrew the drive motor end cover;



② Screw the M6 nut into the M6*25 bolt, see Figure2 below;



③ Screw the M6*25 bolt into the screw holes in the brake disc, see Figure3 ;



④ Using a wrench to turn the nut counter-clockwise. When the brake clearance is greater than 0.003in (0.08 mm), the brake is released.



⑤ Repeat the above procedure on opposite drive motor. With both drive motor brake released the machine can be moved manually.

⑥ After moving the machine, reinstall both drive motors to the original conditions.

8.2 Transport Safety

- 1) Chock the machine wheels when preparing for transport.
- 2) Retract and secure the extending platform.
- 3) Switch the key switch to the OFF position and take out the key before transporting the machine. Disconnect and remove the platform control box. Store in a safe location prior to transporting the machine.
- 4) Ensure the front and rear wheels are securely chocked and the machine is inspected to ensure there are no loose or unsecured parts.
- 5) Secure the machine on the transport surface using the tie down areas on the chassis.

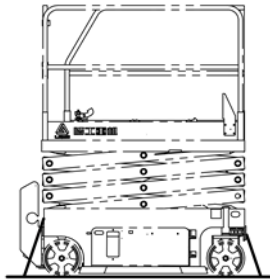

- 6) Use at least four chains or tie straps.

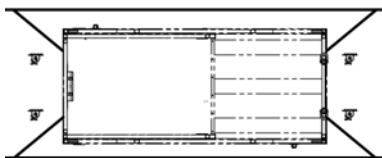

- 7) Be sure to use chains or tie straps of sufficient load capacity.

- 8) Secure the folded guard rail (if any) with a tie strap before transport



Obey the following instructions.

- Only personnel qualified in loading and transporting heavy equipment can rig lifting equipment and lift the machine.

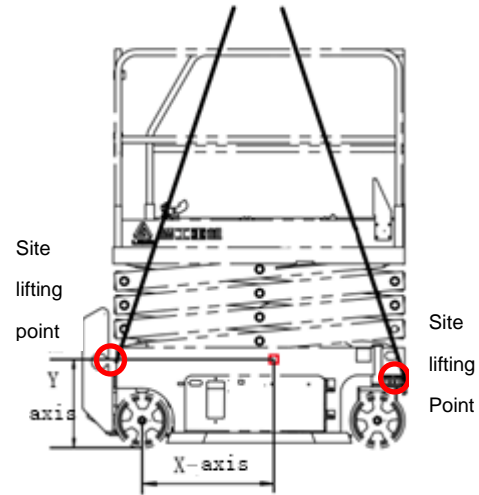

Table 11 - Center of Gravity

Model	X-axis	Y-axis
SS1432E	22.29in (566.2mm)	19.88in (504.95mm)
SS1932E	32.88in (835.1mm)	22.8in (579.4mm)
AS2632E	33.9in (860.2mm)	25.4in (645.6mm)
AS4046E	47.32in (1202mm)	26.9in (683.15mm)

- Only personnel qualified in forklift operation qualification are permitted to load and unload the machine with a forklift.
- Ensure that the lifting capacity, loading surface, loading straps, or rope of the crane is sufficient to bear the machine weight. For serial number, please refer to the nameplate.

8.3 Loading the Machine with a Forklift

- 1) Be sure to secure the extending platform, the controller and the chassis tray. Remove all movable components from the machine.
- 2) Completely lower the platform. Keep the platform folded in each transport process.
- 3) Use the forklift pockets on both sides of the ladder.

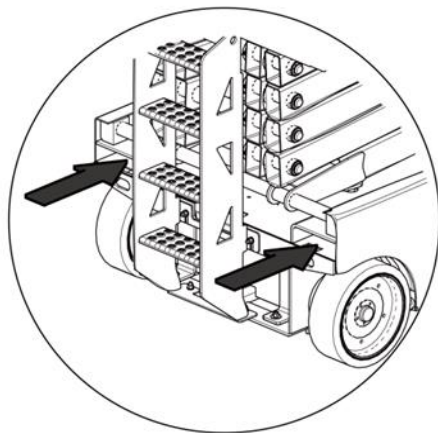

- 4) Place the forks of the forklift into the forklift pockets.
- 5) Drive the forklift forward to completely insert the fork into the pockets.
- 6) Lift the machine by 6in (15cm) and slightly tilt the fork backward to keep the machine

stable.

- 7) Keep the machine level when lowering the fork.



Component damage may result from the machine being lifted from its' side.

8.4 Lifting Precautions

- 1) Completely lower the platform. Be sure to secure the extending platform, the controller and the chassis tray. Remove all movable components from the machine.



Use the center of gravity shown on the lifting decal on the machine.

- 2) The spreader can only be attached to the specified lifting point on the machine shown.
- 3) There are two lifting holes in the front panel of the machine, and there are two lifting holes in the rear end board to use for lifting the machine.
- 4) Adjust the lock tool in such a way that the machine is not damaged and the machine is kept horizontal.

8.5 Parking and Storage

Follow the parking and storage instructions below:

- 1) Drive the machine to a well-protected and well-ventilated area.
- 2) Be sure to completely lower the platform.
- 3) Push the emergency stop switch in to the OFF position.
- 4) If necessary, cover the control panel and the warning signs to protect them against the environment.
- 5) If the machine is parked for a long period, cover the wheels on both sides with a blocking board.
- 6) Turn the power supply selector switch to the OFF position and pull out the key to avoid starting and unauthorized use of equipment.
- 7) If equipped with the optional anti-vandalism package, the working station and ground control box can be covered and locked to prevent vandalism.



This page left blank intentionally

Chapter 9 Decals and Warning Labels

SS1432E Decal Diagram

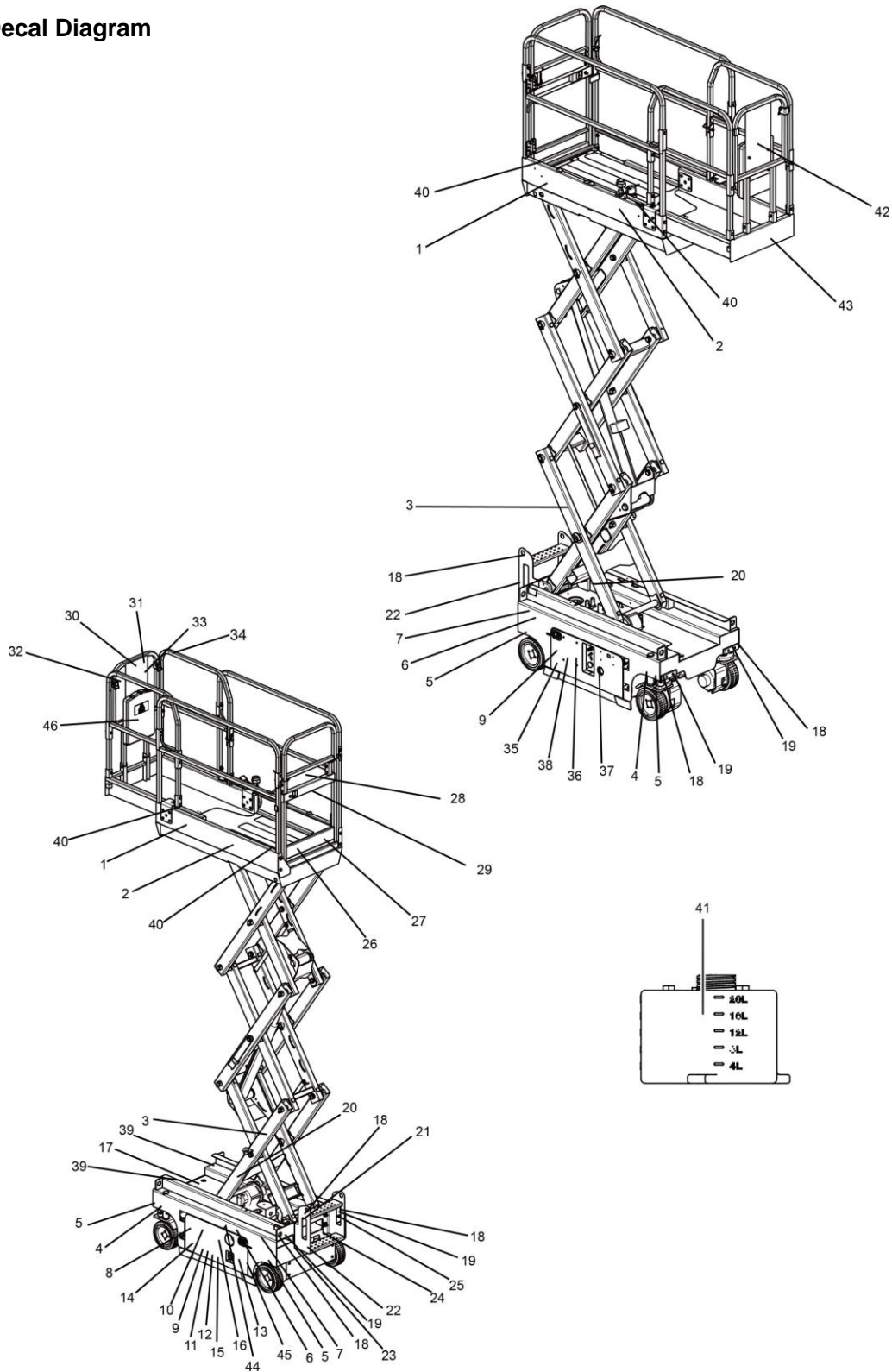





SS1432E Decal List

Item #	Description	Item #	Description
1	Company Logo	24	Battery charging sign
2	Model identification	25	Whole machine nameplate
3	Stay away from machine sign	26	Platform safety warning mark
4	Arrow indication sign	27	Maximum manual force sign
5	Wheel load capacity sign	28	Instructions sign
6	Pressure hazard identification	29	Operation sign
7	Electric shock hazard	30	Description of file loss
8	Safety rules description sign	31	Annual inspection instruction
9	Close the chassis bracket warning sign	32	Reduce platform warning sign
10	Warning signs for explosive burns	33	Direction indicator sign
11	Battery charging sign	34	Suspension position sign
12	Warning sign	35	Prohibition of sparks sign
13	Notices indication	36	Attention in overhaul
14	Battery connection indicator identification	37	Indicator for lower control panel
15	Battery for counterweight warning sign	38	Attention mark of skin infraction
16	Turn off the power sign	39	Forklift Fork Position
17	Tilting hazard sign	40	Tilting hazard sign
18	Hanger sign	41	Oil position sign
19	Lifting Position	42	Company logo
20	Forklift safety arm sign	43	Warning line
21	Electric shock sign	44	Danger statement
22	Transportation sign	45	Annual Inspection
23	Emergency drop mark	46	Indoor Only

SS1432E Decals

1-2534000335	2-2534001109	2-2534001108	3-2534000973	4-2534000102	5-2534001042
	SS1432E	SS1230E			
6-2534000977	7-2534000982	8-2534000984	9-2534000979	10-2534000988	11-2534000990
12-2534001004	13-2534000983	14-2534001035/4	15-2534001037/6	16-2534001056	17-2534000987
18-2831990027	19-2534000828	20-2534000992	21-2534000976	22-2534000021	23-2534000981
24-2534000827	25-2534001126	26-2534001074/271	27-2534001107/6	28-2534000986	29-2534000997
30-2534001015	31-2534001016	32-2534000985	33-2534000033	34-2534000975	35-2534000998
36-2534000974	37-2534000808	38-2534000980	39-2534000101	40-253400017	41-2534000100

42-2534000220	43-2534000024	44-2534000978	45-1720100001	46-1720100002	
					

SS1932E Decal Diagram

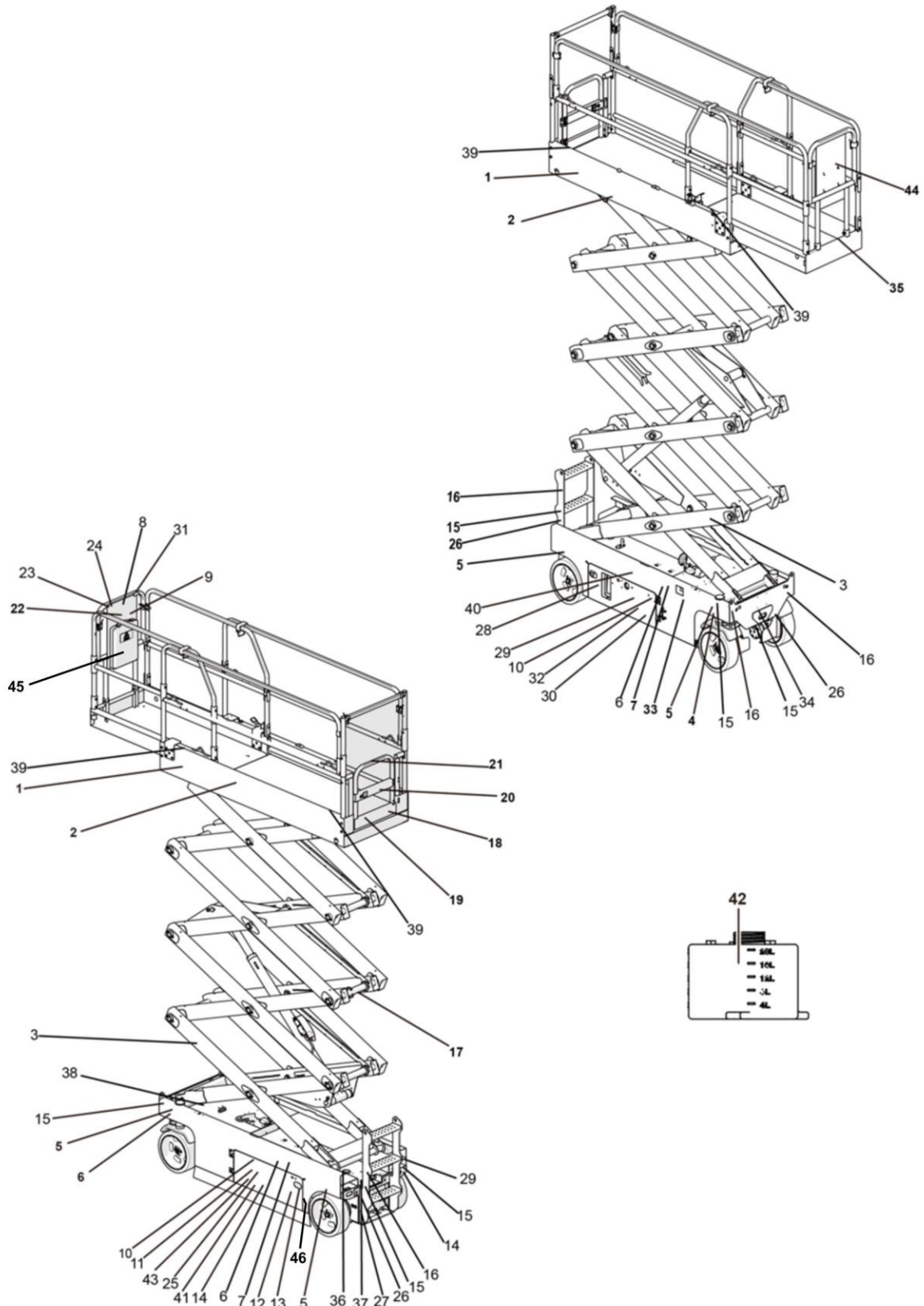





SS1932E Decal List

Item	Description	Item	Description
1	Company Logo	24	Description of file loss
2	Model identification	25	Annual inspection instruction
3	Stay away from machine sign	26	Transportation sign
4	Arrow indication sign	27	Electric shock sign
5	Wheel load capacity sign	28	Indicator for lower control panel
6	Pressure hazard identification	29	Prohibition of sparks sign
7	Electric shock hazard	30	Attention in overhaul
8	Notices indication	31	Suspension position sign
9	Safety rules description sign	32	Attention mark of skin infraction
10	Close the chassis bracket warning sign	33	Emergency drop mark
11	Warning signs for explosive burns	34	Whole machine nameplate
12	Battery charging sign	35	Warning line
13	Warning sign	36	Forklift Fork Position
14	Battery connection indicator identification	37	Battery charging sign
15	Hanger sign	38	Tilting hazard sign
16	Lifting Position	39	Lanyard Anchorage Point
17	Forklift safety arm sign	40	Danger description
18	Maximum manual force sign	41	Turn off power identification
19	Platform safety warning mark	42	Oil position sign
20	Operation sign	43	Battery for counterweight warning sign
21	Instructions sign	44	Company Logo
22	Reduce platform warning sign	45	Annual Inspection
23	Direction indicator sign	46	Indoor Only

SS1932E Decals

1-2534000335	2-2534001198	3-2534000973	4-2534000102	5-2534001089	6-2534000977
7-2534000982	8-2534000983	9-2534000984	10-2534000979	11-2534000988	12-2534000990
13-2534001004	14-2534001035	15-2831990027	16-2534000828	17-2534000032	18-2534001107
19-2534001074	20-2534000997	21-2534000986	22-2534000985	23-2534000033	24-2534001015
25-2534001016	26-2534000021	27-2534000976	28-2534000808	29-2534000998	30-2534000974
31-2534000975	32-2534000980	33-2534000981	34-2534001126	35-2534000024	36-2534000101
37-2534000827	38-2534000987	39-2534000017	40-2534000978	41-2534001056	42-2534000100





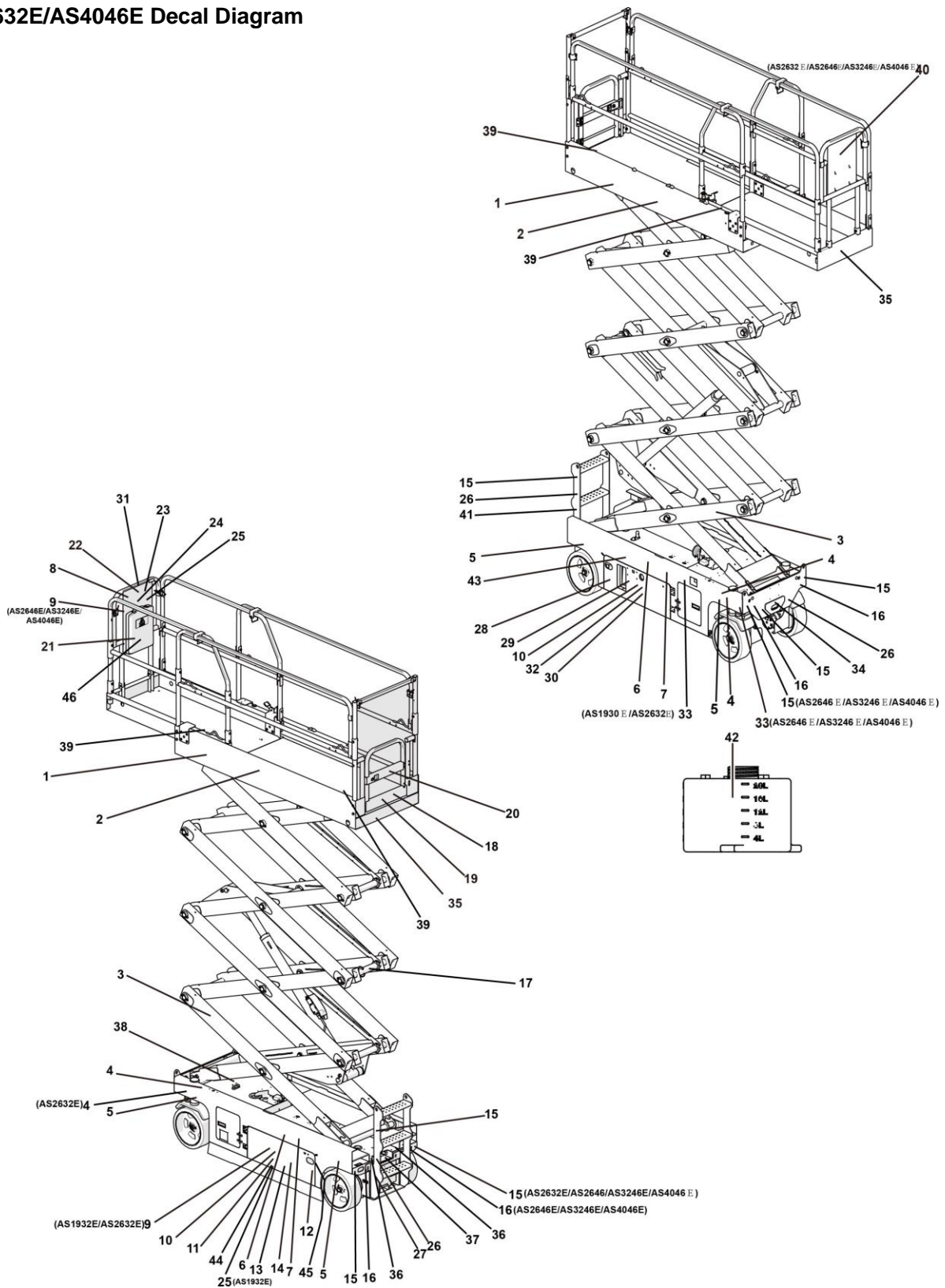





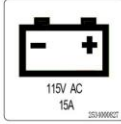

43-2534001037	44-2534000220	45-1720100001	46-1720100002		
					

AS2632E/AS4046E Decal Diagram



AS2632E/AS4046E Decal List

Code	Name	Code	Name
1	Company Logo	24	Description of file loss
2	Model identification	25	Annual inspection instruction
3	Stay away from machine sign	26	Transportation sign
4	Arrow indication sign	27	Electric shock sign
5	Wheel load capacity sign	28	Indicator for lower control panel
6	Pressure hazard identification	29	Prohibition of sparks sign
7	Electric shock hazard	30	Attention in overhaul
8	Notices indication	31	Suspension position sign
9	Safety rules description sign	32	Attention mark of skin infraction
10	Close the chassis bracket warning sign	33	Emergency drop mark
11	Warning signs for explosive burns	34	Whole machine nameplate
12	Battery charging sign	35	Warning line
13	Warning sign	36	Forklift Fork Position
14	Battery connection indicator identification	37	Battery charging sign
15	Hanger sign	38	Tilting hazard sign
16	Lifting Position	39	Lanyard Anchorage Point
17	Forklift safety arm sign	40	Company Logo
18	Maximum manual force sign	41	Brake release safety sign
19	Platform safety warning mark	42	Oil position sign
20	Operation sign	43	Danger description
21	Instructions sign	44	Battery for counterweight warning sign
22	Reduce platform warning sign	45	Annual Inspection
23	Direction indicator sign	46	Indoor Only

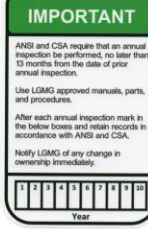
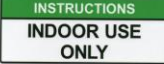
<p>36-2534000101</p> 	<p>37-2534000827</p> 	<p>38-2534000987</p> 	<p>39-2534000017</p> 	<p>40-2534000220</p> 	<p>41-2534001032</p> 
<p>41-2534000991</p> 	<p>42-2534000100</p> 	<p>43-2534000978</p> 	<p>44-2534000989</p> 	<p>44-2534001021</p> 	<p>44-2534001038</p> 
<p>44-2534001117</p> 	<p>45-1720100001</p> 	<p>46-1720100002</p> 			

Chapter 10 Specifications

Table 12 - Platform Load Capacity

Model	AS1432E			
Maximum occupant capacity	indoor	2	outdoor	-
Maximum working load of platform	indoor	510lbs	outdoor	-
Maximum working load of extending platform	indoor	265lbs	outdoor	-
Model	SS1932E			
Maximum occupant capacity	indoor	2	outdoor	-
Maximum working load of platform	indoor	510lbs	outdoor	-
Maximum working load of extending platform	indoor	265lbs	outdoor	-
Model	AS2632E			
Maximum occupant capacity	indoor	2	outdoor	-
Maximum working load of platform	indoor	510lbs	outdoor	-
Maximum working load of extending platform	indoor	265lbs	outdoor	-
Model	AS4046E			
Maximum occupant capacity	indoor	2	outdoor	-
Maximum working load of platform	indoor	705lbs	outdoor	-
Maximum working load of extending platform	indoor	265lbs	outdoor	-

Table 13 - SS1432E Operating Specifications

Item	Parameter	
Maximum working height	20.7ft (6.3m)	
Maximum height of platform	14.1ft (4.3m)	
Extending size of platform	2ft (0.6m)	
Traveling speed of machine (Stowed position)	2.2mph (3.5Km/h)	
Traveling speed of machine (lifting position)	0.3mph (0.5Km/h)	
Lifting/lowering speed (S)	25/20	
Minimum turning radius (exterior wheel)	4.9ft (1.5m)	
Gradeability	25%	
Overall length	With ladder	5ft (1.53m)
	Without ladder	4.4ft (1.35m)
Overall width	2.65ft (0.81m)	
Tire size (diameterxwidth)	9.1inx3.1in (230mmx80mm)	
Dimension of working platform (LxW)	4.4ftx2.3ft (1.35mx0.7m)	
Wheelbase (front/rear)	44.1in(1120mm)	
Ground clearance (stowed/lifting position)	1.97in/0.63in (50mm/16mm)	
Overall height	Rails Folding	6.2ft (1.9m)
	Rails un-folding	7.1ft (2.15m)
Overall weight	2172lbs (985Kg)	
Battery	Output Voltage(V)	12
	Capacity (AH)	25A/280;75A/70
Charger	Nominal AC Input Voltage	100-240VAC
	Maximum DC Output Current	30
	Nominal DC Output Voltage	24
Ground environment noise radiation	< 70dBA	
Platform environment noise radiation	< 70dBA	
System pressure	2174psi (15MPa)	
Tire contact pressure	213.4psi (1471.5KPa)	
Ground pressure	228.5psf (10.94KPa)	

Table 14 - SS1932E Operating Specifications

Item		Parameter
Maximum working height		24.6ft (7.5m)
Maximum height of platform		18ft (5.5m)
Extending size of platform		2ft (0.6m)
Max Traveling speed (Stowed)		2.2mph (3.5Km/h)
Max Traveling speed (Elevated)		0.3mph (0.5Km/h)
Lifting/lowering speed (S)		32/27
Minimum turning radius (Exterior)		4.9ft (1.5m)
Gradeability		25%
Overall length	With ladder	5.02ft (1.53m)
	Without ladder	4.4ft (1.35m)
Overall width		2.65ft (0.81m)
Tire size (diameterxwidth)		9.1inx3.1in (230mmx80mm)
Dimension of working platform (LxW)		4.4ftx2.3ft (1.35mx0.7m)
Wheelbase (front/rear)		44.1in(1120mm)
Ground clearance (stowed/lifting position)		1.97in/0.63in (50mm/16mm)
Overall height	Rails Folding	6.56ft (2.0m)
	Rails un-folding	7.46ft (2.28m)
Overall weight		2866lbs (1300Kg)
Battery	Output Voltage(V)	12
	Capacity (AH)	25A/280;75A/70
Charger	Nominal AC Input Voltage	100-240VAC
	Maximum DC Output Current	30
	Nominal DC Output Voltage	24
Ground environment noise radiation		< 70dBA
Platform environment noise radiation		< 70dBA
System pressure		2176psi (15MPa)
Tire contact pressure		211psi(1454.66KPa)
Ground pressure		281.1psf(13.46Kpa)

Table 15 - AS2632E Operating Specifications

Item		Parameter
Maximum working height		32.8ft (10m)
Maximum height of platform		26.2ft (8m)
Extending size of platform		3ft (0.9m)
Max Traveling speed (Stowed)		2.2mph (3.5Km/h)
Max Traveling speed (Elevated)		0.5mph (0.8Km/h)
Lifting/lowering speed (S)		31/40
Minimum turning radius (exterior)		7ft (2.15m)
Gradeability		25%
Overall length	With ladder	7.9ft (2.4m)
	Without ladder	7.4ft (2.25m)
Overall width		2.7ft(0.83m)
Tire size (diameterxwidth)		15inx5.1in 380mmx130mm
Dimension of working platform (LxW)		7.4ftx2.7ft (2.26mx0.81m)
Wheelbase (front/rear)		73in(1850mm)
Ground clearance (stowed/lifting position)		3.94in/0.98in (100mm/25mm)
Overall height	Rails Folding	6.4ft (1.95m)
	Rails un-folding	7.6ft (2.32m)
Overall weight		4718lbs (2140Kg)
Battery	Output Voltage(V)	6
	Capacity (AH)	25A/447;75A/115
Charger	Nominal AC Input Voltage	100-240VAC
	Maximum DC Output Current	30
	Nominal DC Output Voltage	24
Ground environment noise radiation		< 70dBA
Platform environment noise radiation		< 70dBA
System pressure		3046psi (21MPa)
Tire contact pressure		126.3psi (871.10KPa)
Ground pressure		264.4psf (12.66KPa)

Table 16 - AS2643E Operating Specifications

Item		Parameter
Maximum working height		32.8ft (10m)
Maximum height of platform		26.2ft (8m)
Extending size of platform		3ft (0.9m)
Traveling speed of machine (Stowed position)		2.5mph (4Km/h)
Traveling speed of machine (lifting position)		0.5mph (0.8Km/h)
Lifting/lowering speed (S)		35/40
Minimum turning radius		7.5ft (2.3m)
Gradeability		25%
Overall length	With ladder	8ft (2.42m)
	Without ladder	7.4ft (2.25m)
Overall width		3.9ft (1.18m)
Tire size (diameterxwidth)		15inx5.1in 380mmx130mm
Dimension of working platform (LxW)		7.4ftx3.8ft (2.26mx1.15m)
Wheelbase (front/rear)		73in(1850mm)
Ground clearance (stowed/lifting position)		3.94in/0.79in (100mm/20mm)
Overall height	Rails Folding	5.7ft (1.73m)
	Rails un-folding	7.5ft (2.30m)
Overall weight		5986lbs (2715Kg)
Battery	Output Voltage(V)	6
	Capacity (AH)	25A/488;75A/132
Charger	Nominal AC Input Voltage	100-240VAC
	Maximum DC Output Current	30
	Nominal DC Output Voltage	24
Ground environment noise radiation		< 70dBA
Platform environment noise radiation		< 70dBA
System pressure		3046psi (21MPa)
Tire contact pressure		177.76psi (1225.62KPa)
Ground pressure		274.5psf (11.85KPa)

Table 17 - AS4046E Operating Specifications

Item		Parameter
Maximum working height		46ft (14m)
Maximum height of platform		39.4ft (12m)
Extending size of platform		3ft (0.9m)
Traveling speed of machine (Stowed position)		1.9mph (3Km/h)
Traveling speed of machine (lifting position)		0.5mph (0.8Km/h)
Lifting/lowering speed (S)		58/60
Minimum turning radius (exterior wheel)		7.5ft (2.3m)
Gradeability		25%
Overall length	With ladder	8.1ft (2.47m)
	Without ladder	7.4ft (2.25m)
Overall width		3.9ft(1.18m)
Tire size (diameterxwidth)		15inx5.1in 380mmx130mm
Dimension of working platform (LxW)		7.4ftx3.8ft (2.26mx1.15m)
Wheelbase (front/rear)		73in(1850mm)
Ground clearance (stowed/lifting position)		3.94in/0.79in (100mm/20mm)
Overall height	Rails Folding	6.5ft (1.99m)
	Rails un-folding	8.4ft (2.56m)
Overall weight		7275lbs (3300Kg)
Battery	Output Voltage(V)	12
	Capacity (AH)	25A/280;75A/70
Charger	Nominal AC Input Voltage	100-240VAC
	Maximum DC Output Current	30
	Nominal DC Output Voltage	24
Ground environment noise radiation		< 70dBA
Platform environment noise radiation		< 70dBA
System pressure		3046psi (21MPa)
Tire contact pressure		190.98psi (1316.78KPa)
Ground pressure		280.07psf (13.41KPa)

10.1 Hydraulic Oil Specifications



When filling the hydraulic oil tank, it is a requirement to use the proper hydraulic oil in accordance with the work site environment and ambient temperature with reference to the following:

- L-HM 32# anti wear hydraulic oil: minimum air temperature $\geq 5^{\circ}\text{F}$ (-15°C).
- L-HM 32# anti wear hydraulic oil: -40°F (-40°C) < minimum air temperature < 5°F (-15°C).
- 10# aviation hydraulic oil: minimum air temperature $\leq -40^{\circ}\text{F}$ (-40°C) ;
- L-HV 32# anti wear hydraulic oil and 10# aviation hydraulic oil: The hydraulic oil suitable for ambient temperature shall be selected pursuant to the order requirements.
- Oil level in the oil tank when SS1432E/SS1932E is stowed after the whole machine has been fully elevated, steered from stop-to-stop, and driven is 1 gal. (4L).

- Oil level in the oil tank when AS2632E is stowed after the whole machine has been fully elevated, steered stop-to-stop, and driven is 2.5 gal. (9.5L).
- Oil level in the oil tank when AS3246E is stowed after the whole machine has been fully elevated, steered from stop-to-stop, and driven: is 3.7 gal. (14L).



The ground bearing information is approximate information, and the different options are not included. The information can be used only if the safety factor is high enough.

- The weight of the machine varies according to the configuration of the selected part.

Chapter 11 Maintenance Schedule

Routine inspection and maintenance interval table

Maintenance level	Routine inspection	Level I	Level II	Level III	Level IV	Level V
Maintenance period	Every day	25h/1m	50h/3m	100h/6m	200h/12m	400h/24m



Notice: Working hours are based on those shown on the hourmeter.

Maintenance items of every level are given in the following tables

Item	Description	Maintenance Level					
		Routine inspection	I	II	III	IV	V
Electric system	Check battery capacity	•	•	•	•	•	•
	Check that all buttons/switches on the PCU panel function normally	•	•	•	•	•	•
	Ensure the PCU emergency stop switch is secure	•	•	•	•	•	•
	Check if all switches operate properly	•	•	•	•	•	•
	Check if any wiring harnesses are damaged	•	•	•	•	•	•
	Ensure the PCU wiring harness connector is secure	•	•	•	•	•	•
	Check if the PCU wiring harness connector is not damaged	•	•	•	•	•	•
	Check if the PCU wiring harness is crimped or damaged	•	•	•	•	•	•
	Check if the pressure switch wiring is secure and not damaged	•	•	•	•	•	•
	Check if the lowering solenoid valve is secure and not damaged	•	•	•	•	•	•
	Check if the wirings of horizon sensor and inclination sensor are secure and not damaged	•	•	•	•	•	•
	Check the position and wiring of every limit switch rocker arm	•	•	•	•	•	•
	Ensure the angle sensor wiring harness	•	•	•	•	•	•

Item	Description	Maintenance Level					
		Routine inspection	I	II	III	IV	V
	and connector are secure and not damaged						
	Ensure the emergency stop switch, key switch and plug switch on the lowering control panel and their wiring are secure and not damaged	•	•	•	•	•	•
	Ensure the warning lamp and horn function normally	•	•	•	•	•	•
	Ensure the motor, motor controller, relay and ECU wirings are secure and not damaged	•	•	•	•	•	•
	Ensure the wiring of every solenoid valve on the main valve block is secure and not damaged	•	•	•	•	•	•
	Ensure the charger wiring is secure and not corroded	•	•	•	•	•	•
	Ensure the battery posts are secure and not corroded	•	•	•	•	•	•
	Check the battery is secure and not damaged	•					
	Check machine performance and various limit switches	•					
	Check if any connector is loose, damaged or corroded	•	•	•	•	•	•
Hydraulic System	Check if the pressure of the hydraulic system is normal	•	•	•	•	•	•
	Check if the lift system hydraulic pressure is normal	•	•	•	•	•	•
	Check if the steering system hydraulic pressure is normal	•	•	•	•	•	•
	Check if the driving system hydraulic pressure is normal	•	•	•	•	•	•
	Check if any oil line or connector is loose or damaged	•	•	•	•	•	•
	Check all hydraulic cylinders for damage or leaking	•	•	•	•	•	•
	Check every hydraulic valve for damage or leaking	•	•	•	•	•	•
	Check if the scissor stack arm oil line is securely fastened or damaged	•	•	•	•	•	•
	Check if the driving oil pipe clip is loose	•	•	•	•	•	•
	Check oil level in the hydraulic tank	•	•	•	•	•	•
	Replace the hydraulic oil	Yearly					



Item	Description	Maintenance Level					
		Routine inspection	I	II	III	IV	V
	Hydraulic oil return filter element	Every 6 months					
	Check the hydraulic oil tank vent cap for leaks	•	•	•	•	•	•
	Replace the hydraulic oil tank vent cap			•	•	•	
Whole machine	Check the fork sliding block for abnormal noise					•	•
	Check and replace the sliding block					•	•
	Check for loose or damaged bolts or abnormal noise	•					
	Check if any circlip or washer on fork arms are damaged, worn, or missing	•					
	Check if the emergency lowering system operates properly	•					
	Check if the platform, scissor stack arm, and chassis are deformed or have broken welds	•					
	Check if the paint is excessively chips or peels off	•					
	Check if the decals and safety signs are correct and legible	•					
	Check if the manuals are with the machine	•					
	Machine performance and limit switches operate properly	•					
Lubrication	Lubricate the steering knuckle	Once a month					

Hydraulic Oil Specifications

Oil type	Use temperature	Remark
L-HM 32# anti wear hydraulic oil	Minimum air temperature $\geq 5^{\circ}\text{F}$ (-15°C)	—
L-HM 32# anti wear hydraulic oil	-40°F (-40°C) < minimum air temperature $< 5^{\circ}\text{F}$ (-15°C)	Select the hydraulic oil suitable for ambient temperature pursuant to the order requirements
10# aviation hydraulic oil	Minimum air temperature $\leq -40^{\circ}\text{F}$ (-40°C)	

Annual Inspection Record

Legend description			
Y=Yes, completed			
N=No, un-completed			
R=Repaired			
Evaluation			
Annual Inspection	Y	N	R
Operation inspection completed			
Maintenance item completed			
Function test completed			
Model			
Serial number			
Manufacturing Date			
Owner			
Inspector			
Title of inspector			
Inspection company			
Inspection Date			
Last Annual Inspection Date			

This page left blank intentionally

Mobile Elevating Work Platform Operation and Safety Manual

First edition – July 2019



LGMG North America Inc.

1445 Sheffler Drive
Chambersburg, PA. 17201
Toll Free: 833.288.LGMG (5464)
Local Phone: 717.889.LGMG (5464)
Email: sales@lmgna.com

www.lmgna.com